



KINECTRICS

a **BWX** company

Low-Frequency Heating Transformer Insulation Drying





Low-Frequency Heating (LFH) for Drying Paper Insulation

What is Low-Frequency Heating (LFH) for Insulation Drying?

- LFH dry-out involves applying a circulating current of approximately 1 Hz to one of the transformer windings, with the oil removed from the transformer to allow simultaneous application of deep vacuum.
- All other windings are short-circuited, which allows heating current to be induced in them. The I^2R losses thereby produced in the windings dry the paper insulation from the inside-out.
- The oil is processed in a separate step to remove moisture and gasses.

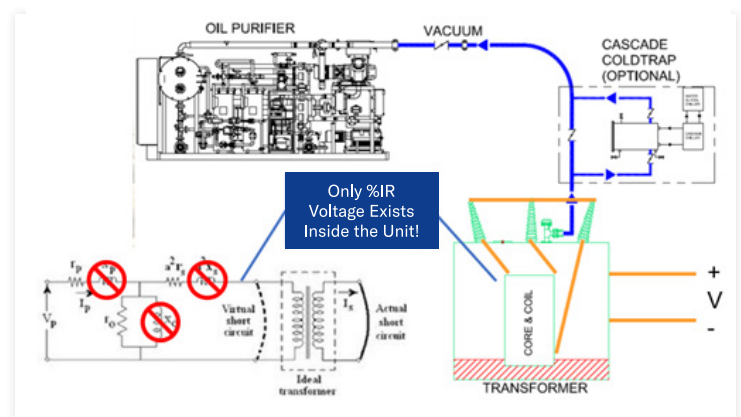

Why Use Low-Frequency Heating (LFH)?

- ✓ The only field-deployable process in which heat and vacuum are applied simultaneously to drive moisture from the paper insulation
- ✓ Fastest and most effective method for field drying of insulating paper and pressboard in a transformer, where the bulk of any moisture resides
- ✓ Ensures that the solid insulation materials in the transformer will be fully dried, not just the oil
- ✓ Fully automated and computer-controlled process to ensure maximum depth and speed of dry-out with no chance of damage to the transformer
 - The winding temperatures are continuously monitored during the LFH process
 - The magnitude and duration of the circulating currents are kept within safe limits to prevent damage to the paper from excessive temperatures and/or rise of temperature
- ✓ An approved method as noted in IEEE Std C57.140-2017, *IEEE Guide for Evaluation and Reconditioning of Liquid Immersed Power Transformers*
- ✓ A recent survey found 9.7% of 85,210 in-service transformers tested had unacceptable moisture levels (> 18% relative saturation).



Transformer Failure & Premature Aging Caused by Moisture in Paper Insulation

Excess moisture in your transformer's paper insulation can lead to the possibility of catastrophic failure of mission-critical transformers.

Moisture-induced failure modes include:

- **Partial discharge damage** due to surface tracking
- Bridging failures caused by **particle accumulation** in areas of high dielectric stress
- **Puncture failure** of thin pressboard components
- Undesirable **chemical reactions** in the tank, i.e. rust
- **Bubble formation** under high load conditions leading to dielectric breakdown

Aside from catastrophic failure mechanisms, moisture is an accelerator of the aging of paper and pressboard insulation and shortens the lifespan of your expensive transformer assets.

Industry estimates indicate that about 10% of in-service power transformers in-service have moisture levels defined as “unacceptable.”



Why is Processing the Insulating Oil Alone Not Sufficient?

- At any given moment, 99% of the moisture in a “wet” transformer resides in the paper insulation, not the oil
- Processing the oil only removes moisture from the oil, not the paper insulation
- Oil processing alone, coupled with a moisture-in-oil measurement, can lead to a false sense of security – dry oil does not necessarily equate to a dry transformer

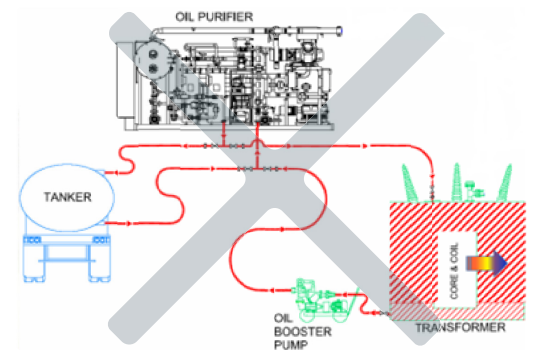

Powering innovative
and sustainable energy
solutions globally.

kinectrics.com

 /kinectrics

 @kinectrics



KINECTRICS
a **BWXT** company